

# Powders & Single Crystals

NOBUGS McStas Training  
October 20th-21st 2016

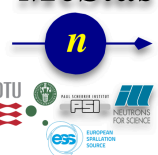

McStas



## ***NOBUGS McStas Training October 2016***

*McStas*

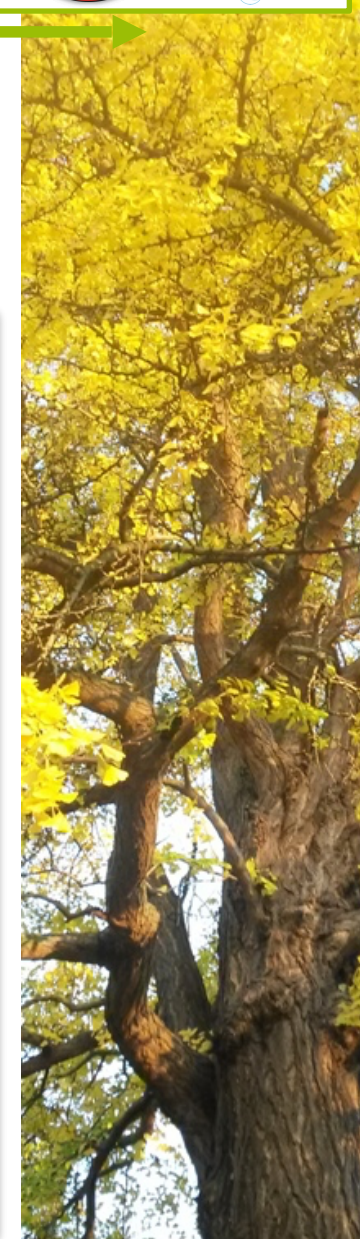



# Caution!

- | We start by a few-slide **hand-waving** introduction to scattering from condensed matter / crystallography which are disciplines in their own right... :-)



- | **Fasten your seat belts!**

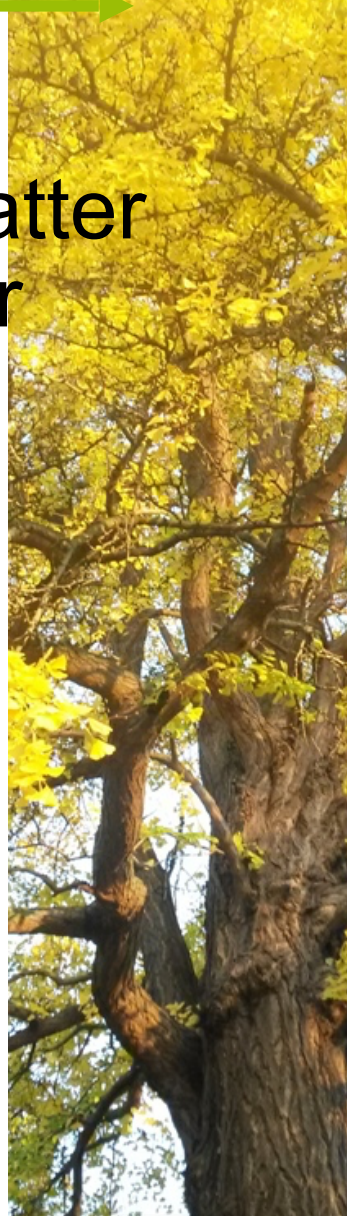
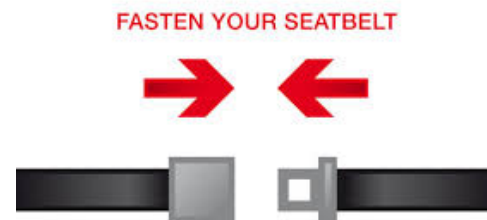



# Sources of further reading...

Others explain the details much better than myself, e.g.:

W. Marshall and S.W. Lovesey. *Theory of Thermal Neutron Scattering*. Oxford, 1971.

G.L. Squires. *Thermal Neutron Scattering*. Cambridge University Press, 1978.

## Neutron Scattering: Theory, Instrumentation, and Simulation

Kim Lefmann  
Niels Bohr Institute, University of Copenhagen  
with contributions from:  
Jacob Kirkensgaard, Lise Arleth, Bente Lebech, and Maria Thomsen, Niels Bohr Institute, Univ. Copenhagen,  
Markus Strobl, European Spallation Source,  
and Andrew Wildes, Institut Laue-Langevin

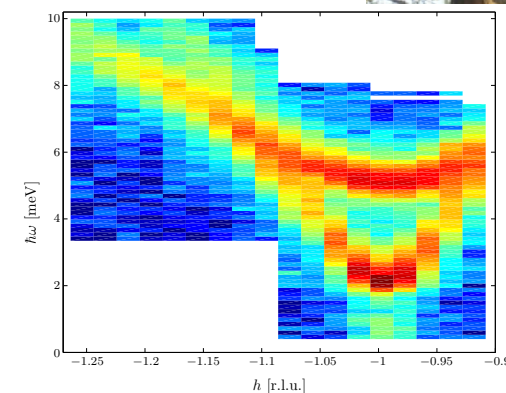

Collection SFN 12 (2010)  
© Owned by the authors, published by EDP Sciences, 2010

**Virtual experiments in a nutshell : simulating neutron scattering from materials within instruments with McStas.**  
E. Farhi<sup>1</sup>, P. Willendrup<sup>2</sup>

<sup>1</sup> Institut Laue Langevin, BP 156, 38042 Grenoble Cedex 9, France  
<sup>2</sup> Risø National Laboratory, Frederiksborgvej 399 P.O. Box 49 DK-4000 Roskilde

**Abstract.** We introduce Monte-Carlo methods for neutron scattering with step-by-step examples, using the *McStas* simulation tool. A selection of neutron instrument components are presented, as well as available sample scattering kernels. All these parts are assembled into more advanced instrument models in order to produce so-called virtual experiments, that is simulations which produce results comparable with experiments. Ways to couple such simulations with other simulation software including molecular dynamics are discussed.





# Single neutron elastic scattering on individual nucleus

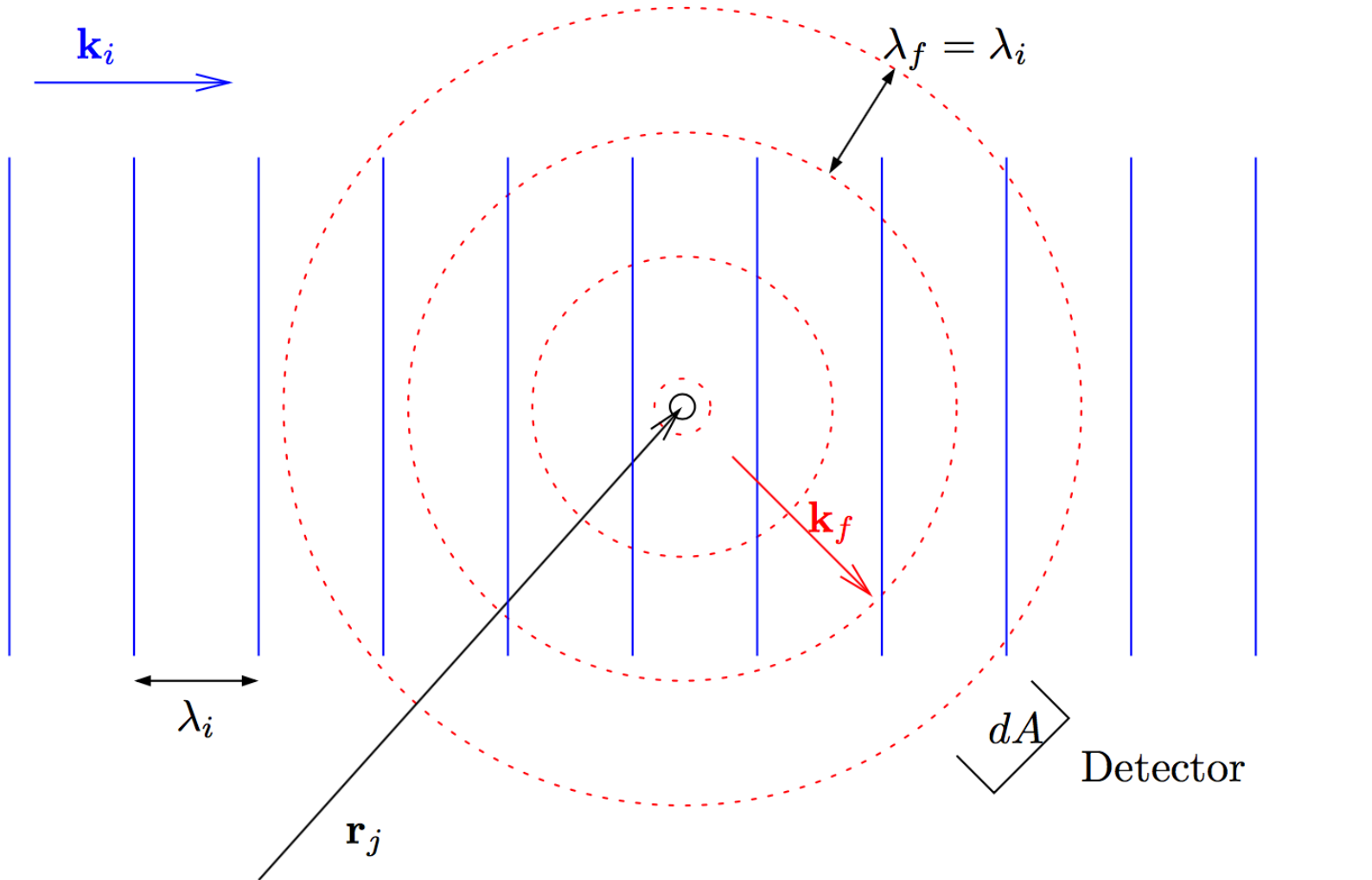

**Figure 2.1:** An illustration of the initial wave,  $\psi_i$ , of wavelength  $\lambda_i$ , and the final wave,  $\psi_f$ , of wavelength  $\lambda_f$ , describing a neutron scattering off a single nucleus with positive scattering length (meaning a phase shift of  $\pi$ ). The area,  $dA$ , for measuring the flux of the outgoing neutrons is the detector area as sketched.

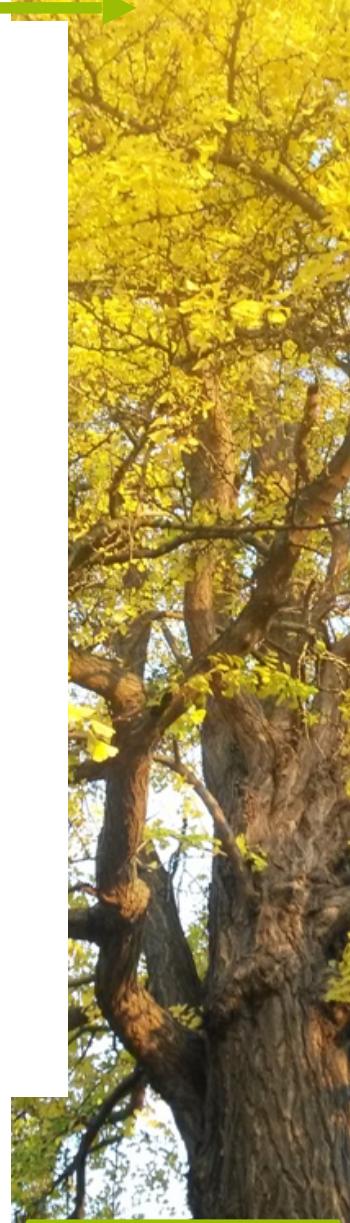



# Interference of elastic scattering from a lattice of nuclei (crystal/crystallite)

1 \$\$

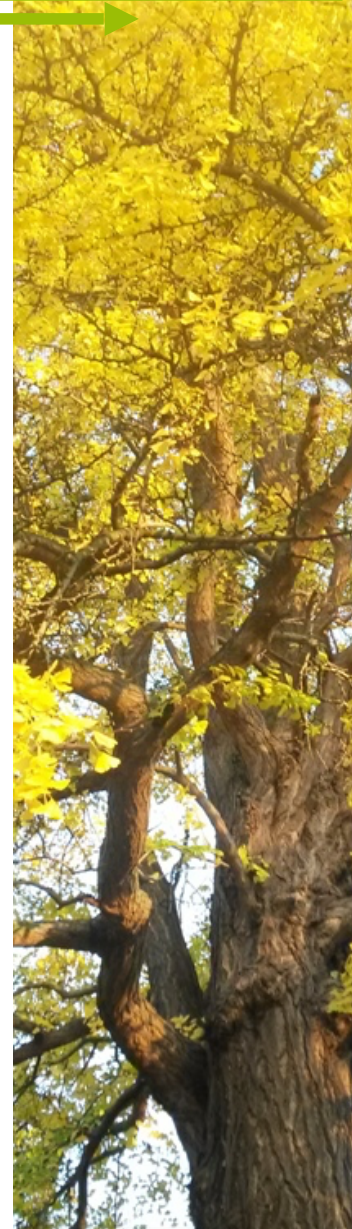
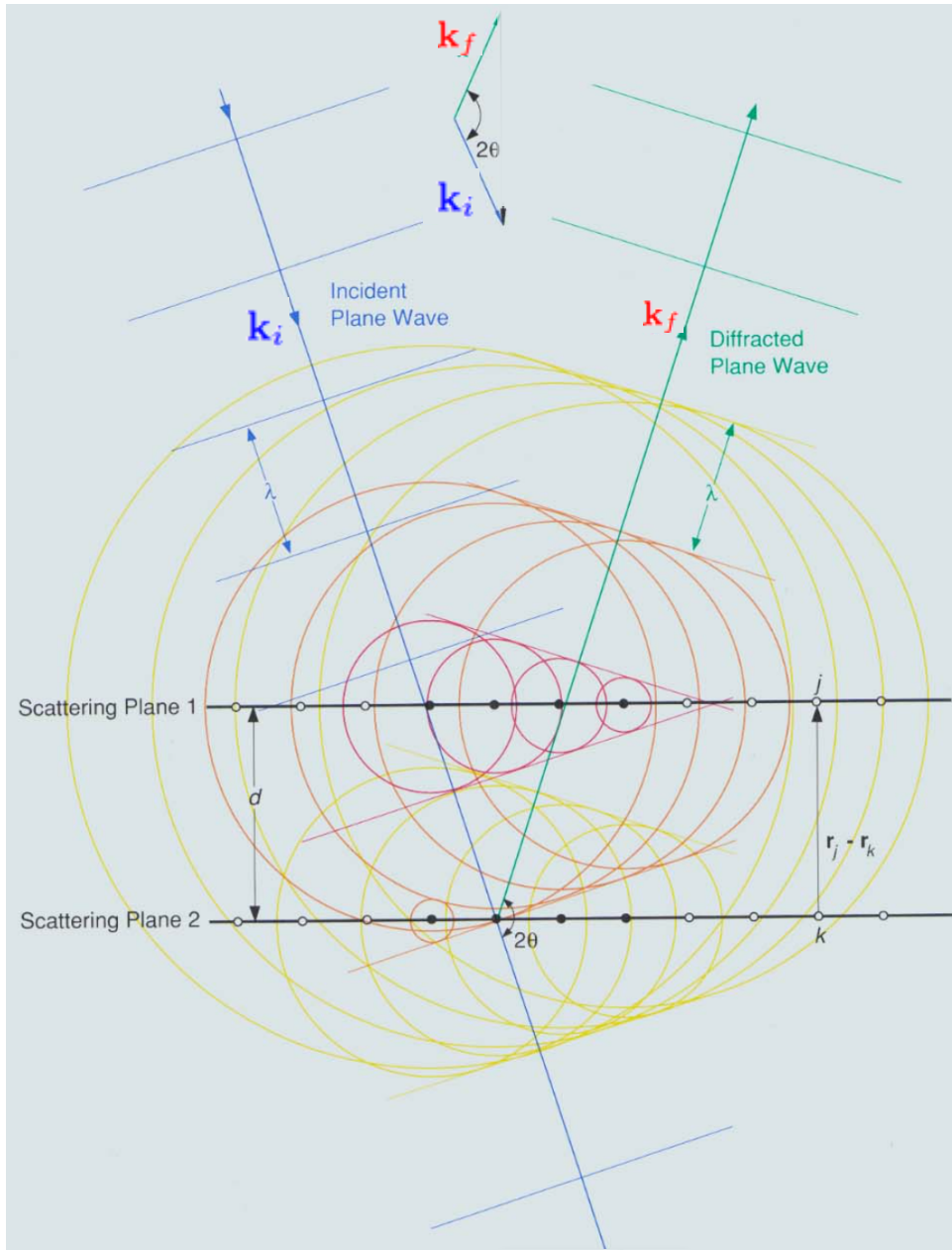

# Interference of elastic scattering from a lattice of nuclei (crystal/crystallite)

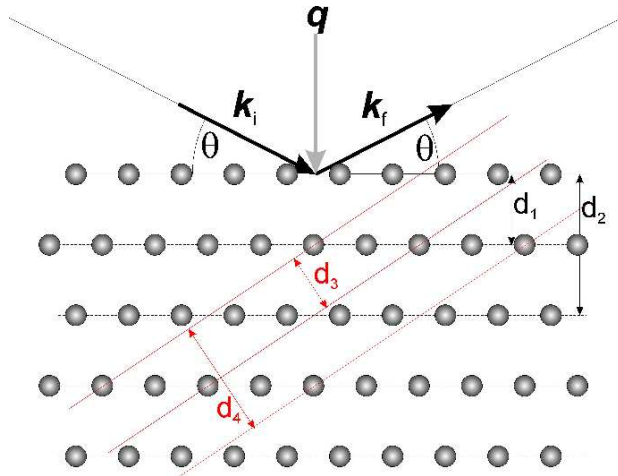

Reciprocal lattice vector  $\tau = \frac{2\pi}{d}$ ,  
 where  $d$  is the lattice spacing of the given reflection.

When  $\tau = q$ , constructive interference between scattering centres occurs,

$$\left. \frac{d\sigma}{d\Omega} \right|_{\text{nucl.el.}} = N \frac{(2\pi)^3}{V_0} \exp(-2W) |F_N(\mathbf{q})|^2 \sum_{\tau} \delta(\mathbf{q} - \tau)$$

Structure factor

...and Bragg scattering can be observed at the the relevant  $2\theta$  angle,

$$n\lambda = 2d \sin(\theta)$$

where  $\lambda$  is the neutron wavelength,  $n$  is the order of the reflection and  $d$  is the lattice spacing

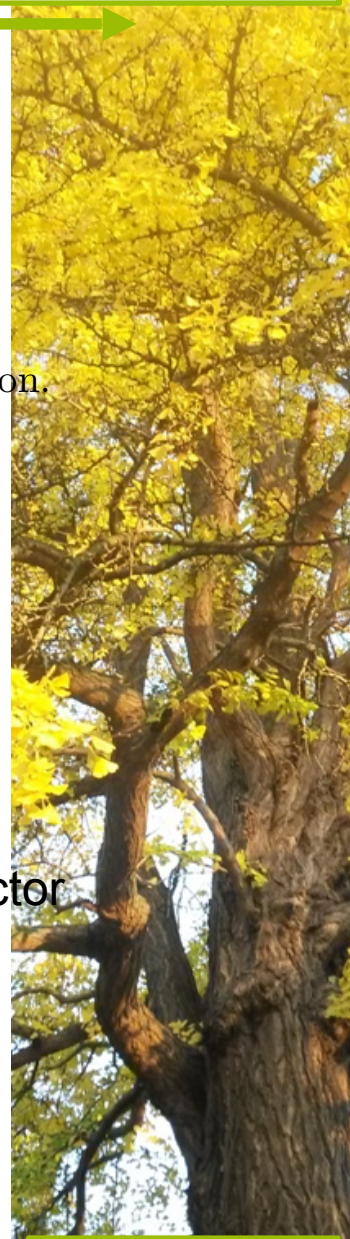



# From single crystal / crystallite to powder

| Single crystal

| Polycrystal with a little disorder, i.e. a *preferred orientation, texture*

| Powder with complete disorder

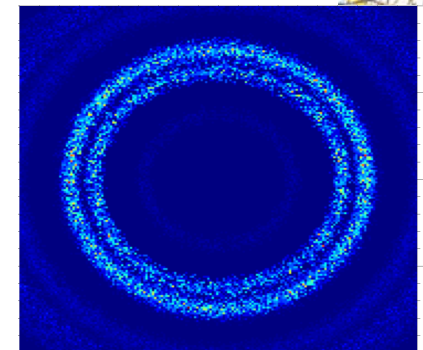
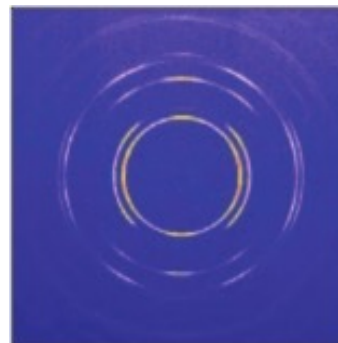
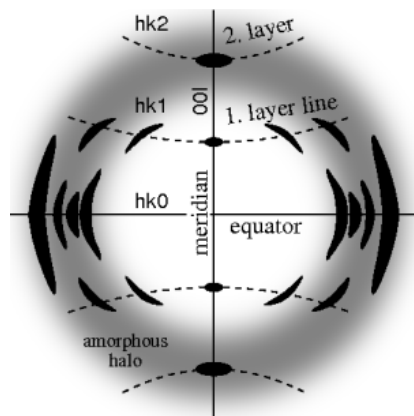
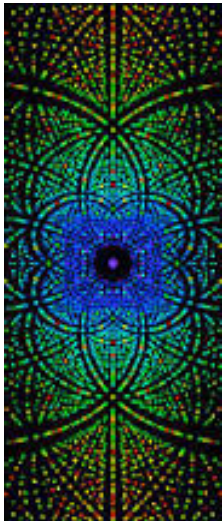



# Lattices - in direct and reciprocal space

## Direct space atomic locations

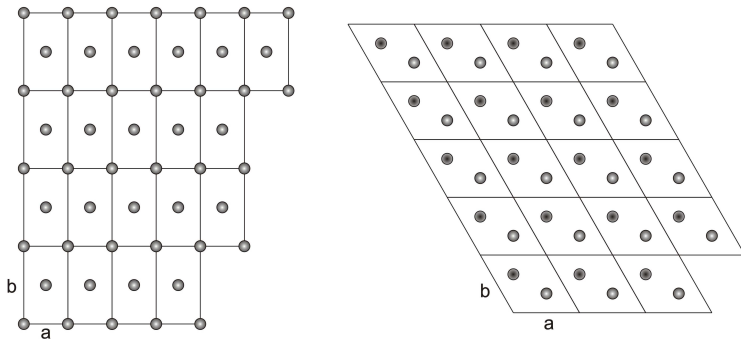
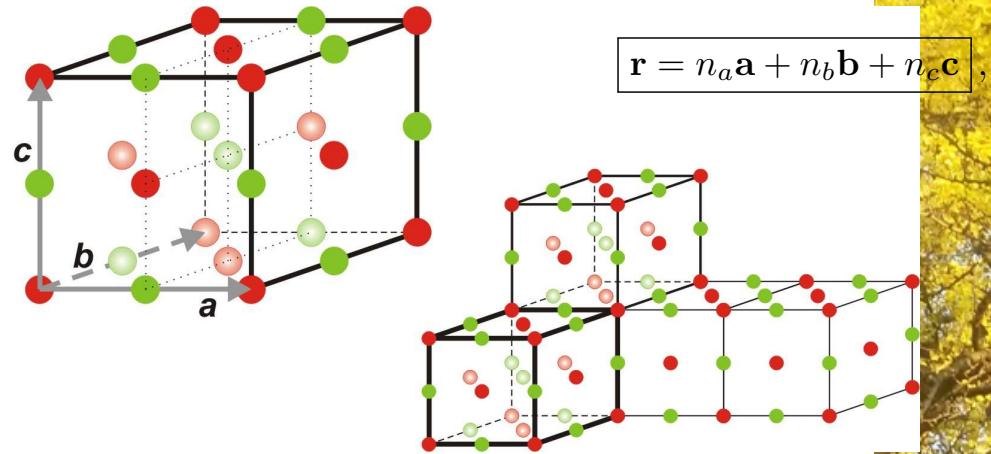

Figure 7.1: Examples of two-dimensional crystals formed by translation of two-dimensional unit cells, each consisting of two atoms, (a)  $a \neq b$ ,  $\gamma = 90^\circ$  and (b)  $a = b$ ,  $\gamma = 120^\circ$ .



## Reciprocal space reflection points...

$$\mathbf{a}^* = \frac{2\pi}{V_0} \mathbf{b} \times \mathbf{c}, \quad \mathbf{b}^* = \frac{2\pi}{V_0} \mathbf{c} \times \mathbf{a}, \quad \mathbf{c}^* = \frac{2\pi}{V_0} \mathbf{a} \times \mathbf{b}.$$

$$\boldsymbol{\tau}_{hkl} = h\mathbf{a}^* + k\mathbf{b}^* + l\mathbf{c}^*.$$

$$d_{hkl} = \frac{2\pi}{|\boldsymbol{\tau}_{hkl}|}.$$

## Each characterised by its Miller indices

$$\sigma_{\boldsymbol{\tau}} = \frac{N(2\pi)^3}{V_0} \frac{2}{k_i} \exp(-2W) |F_N(\boldsymbol{\tau})|^2 \delta(\boldsymbol{\tau}^2 - 2k_i \boldsymbol{\tau} \cos(\omega)).$$



Structure factor



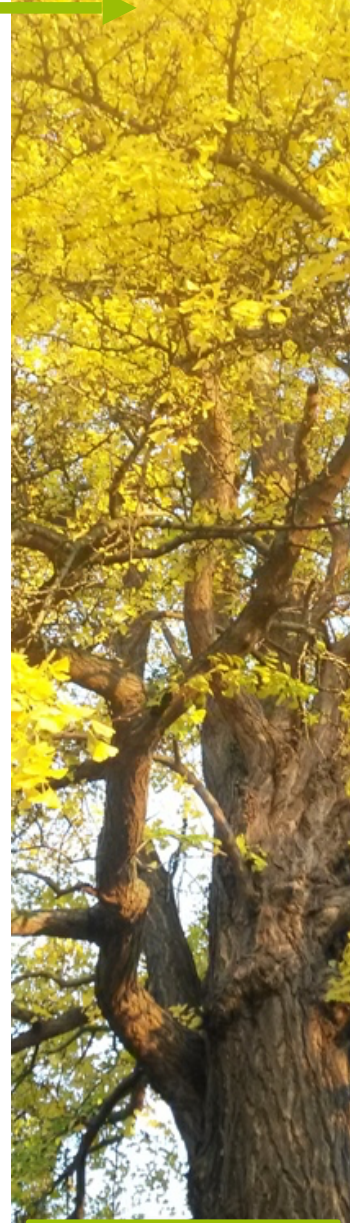

# Input for the Single\_crystal

```
# TITLE *Aluminum-Al-[FM3-M] Miller, H.P.jr.;DuMond, J.W.M.[1942] at 298 K
# CELL 4.049320 4.049320 4.049320 90.000000 90.000000 90.000000
# SPCGRP F M 3 M CUBIC STRUCTURE
# ATOM AL 1 0.000000 0.000000 0.000000
# SCATTERING FACTOR COEFFICIENTS: AL F= 0.345 CM-12
# Reference: Physical Review (1940) 57, 198-206
#
# Physical parameters:
# sigma_coh 1.495 coherent scattering cross section (single atom) in [barn]
# sigma_inc 0.0082 incoherent scattering cross section (single atom)in [barn]
# sigma_abs 0.231 absorption scattering cross section (single atom) in [barn]
# density 2.70 in [g/cm^3]
# weight 26.98 in [g/mol] (single atom)
# multiplicity 4 in [atoms/unit cell]
# Vc 66.4 volume of unit cell in [A^3]
# v_sound 5100 in [m/s]
# v_sound_l 6420 velocity of longitudinal sound in [m/s]
# v_sound_t 3040 velocity of transversal sound in [m/s]
# T_m 933.5 melting temperature in [K]
# T_b 2792.2 boiling temperature in [K]
# At_number 13 atomic number Z
# lattice_a 4.04932 lattice parameter a in [Angs]
#
# Format parameters: Crystallographica format
# column_j 4 multiplicity 'j'
# column_d 5 d-spacing 'd' in [Angs]
# column_F2 7 norm of scattering factor |F|^2 in [fm^2]
# column_h 1
# column_k 2
# column_l 3
#
# h k l Mult. d-space 2Theta F-squared
-1 -1 -1 8 2.338 24.6973 21.3
-1 -1 1 8 2.338 24.6973 21.3
...
```



# Debye-Scherrer cones

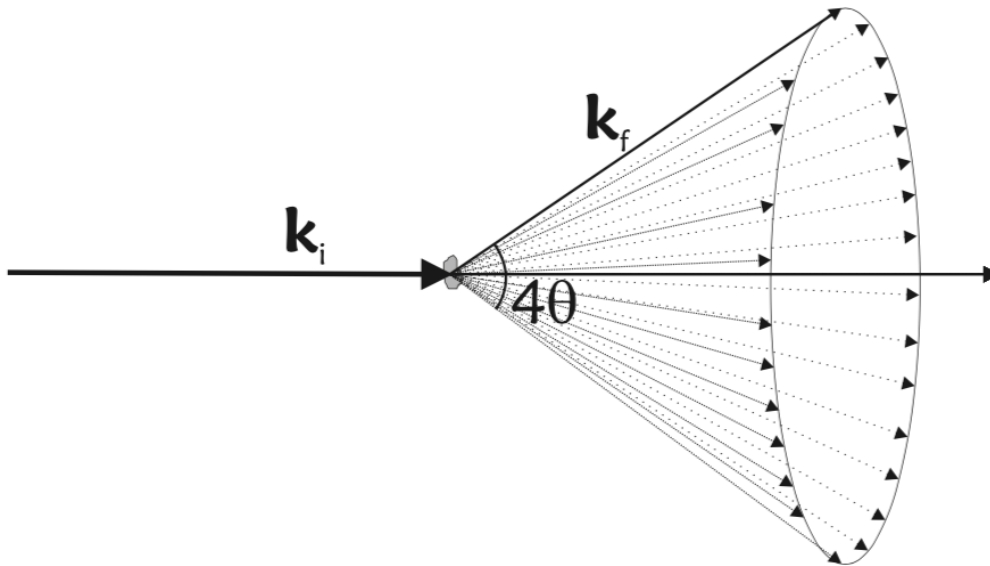

**Figure 7.10:** Illustration of the Debye-Scherrer cone for the diffraction from one powder line.

The textbook expression for the scattering cross section corresponding to one Debye-Scherrer cone reads [Squ78, ch.3.6], with  $V = NV_0$  being the total sample volume:

$$\sigma_{\text{cone}} = \frac{V}{V_0^2} \frac{\lambda^3}{4 \sin \theta} \sum_Q |F(Q)|^2.$$

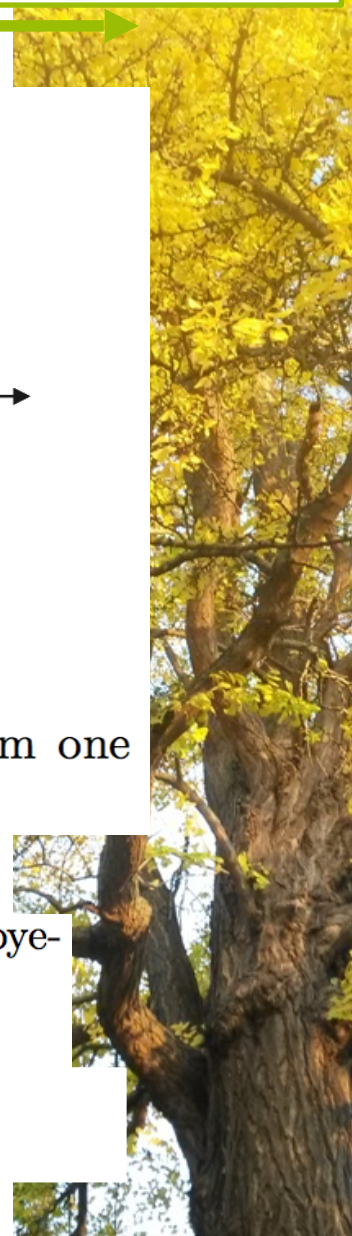



# Input for the PowderN

```
# TITLE *Corundum-Al2O3-[R3-CH] Graafsma, H.;Souhassou, M.;Harkem[1998] [corundum sapphire:blue, ruby:red]
# CELL 4.757000 4.757000 12.987700 90.000000 90.000000 120.000000
# SPCGRP R -3 C TRIGONAL STRUCTURE
# ATOM AL 1 0.000000 0.000000 0.352110
# ATOM O 1 0.306260 0.306260 0.250000
# SCATTERING FACTOR COEFFICIENTS: AL F= 0.345 CM-12 ; O F= 0.581 CM-12
# Reference: Acta Crystallographica B (1998) 54, 193-195
#
# Physical parameters:
# sigma_coh 15.683 coherent scattering cross section for Al2O3 in [barn]
# sigma_inc 0.0188 incoherent scattering cross section for Al2O3 in [barn]
# sigma_abs 0.4625 absorption scattering cross section for Al2O3 in [barn]
# density 4.05 in [g/cm^3]
# weight 101.96 in [g/mol] for Al2O3
# multiplicity 6 in [Al2O3/unit cell]
# Vc 254.52 volume of unit cell in [A^3]
# T_m 2273 melting temperature in [K]
# T_b 3773 boiling temperature in [K]
# lattice_a 4.757 lattice parameter a in [Angs]
# lattice_c 12.9877 lattice parameter c in [Angs]
# lattice_cc 120 lattice angle gamma in [deg]
#
# Format parameters: Lazy format <http://icsd.ill.fr>
# column_j 17 multiplicity 'j'
# column_d 6 d-spacing 'd' in [Angs]
# column_F 13 norm of scattering factor |F| in [barn]
# column_h 1
# column_k 2
# column_l 3
#
# H K L THETA 2THETA D VALUE 1/D**2 SIN2*1000 H K L INTENSITY /F(HKL) A(HKL) B(HKL) PHA.ANG. MULT LPG
1 0 1 6.35 12.71 4.5175 0.0490 12.25 1 0 1 367.0 4.1 -4.08 0.00 180.00 6 82.14
0 0 3 7.10 14.20 4.0467 0.0611 15.27 0 0 3 110.0 4.3 4.32 0.00 0.00 2 66.01
0 1 2 7.57 15.13 3.7972 0.0694 17.34 0 1 2 10.9 0.8 0.84 0.00 0.00 6 58.18
...

```





# Where to get these files...

- | \$MCSTAS/data
  - | Windows: c:\mcstas-2.3\lib\data
  - | Linux: /usr/(local)/share/mcstas/2.3/data
  - | OS X: /Applications/McStas-2.3/Contents/Resources/mcstas/2.3/data
- | - Or make your own via
  - | Finding a CIF file for the given structure
    - | e.g. from ICSD <http://icsd.fiz-karlsruhe.de>
  - | Process it using
    - | cif2hkl at <http://barns.ill.fr/cif2hkl.html>
    - | Crystallographica, using the guide
      - | <https://github.com/McStasMcXtrace/McCode/wiki/Single-crystal---and-generating-its-input>

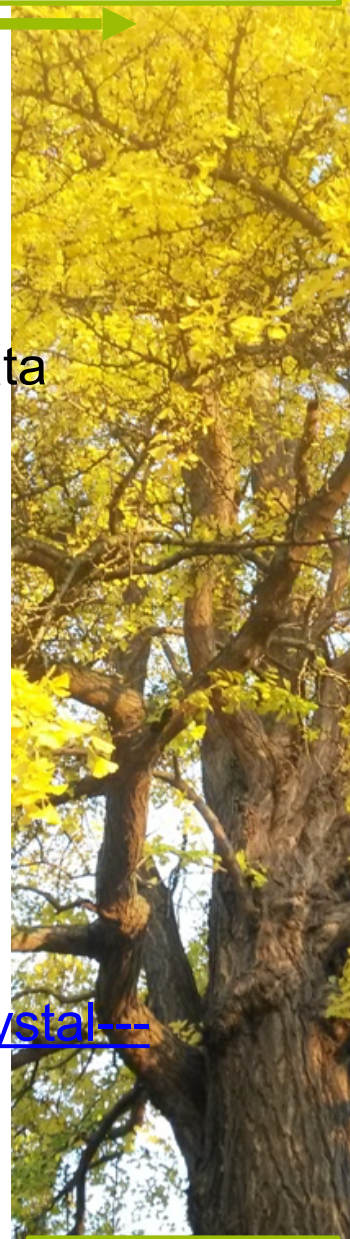



# Laue diffractometers

... for single crystal diffraction

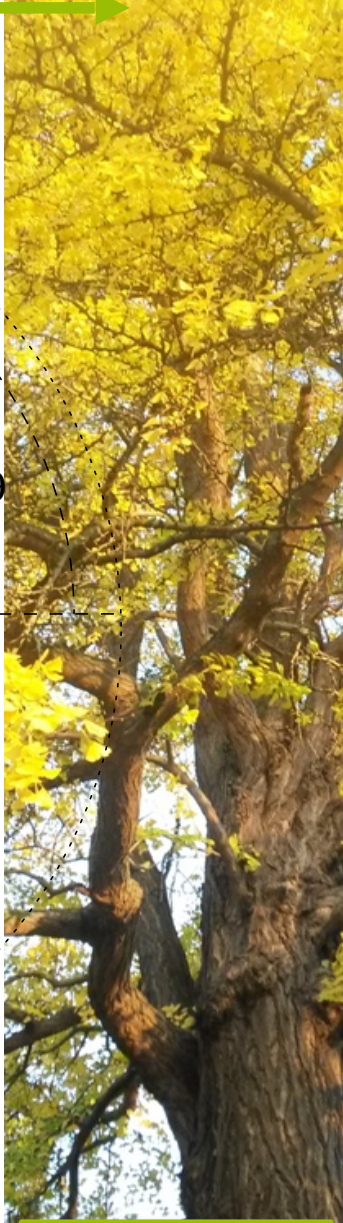
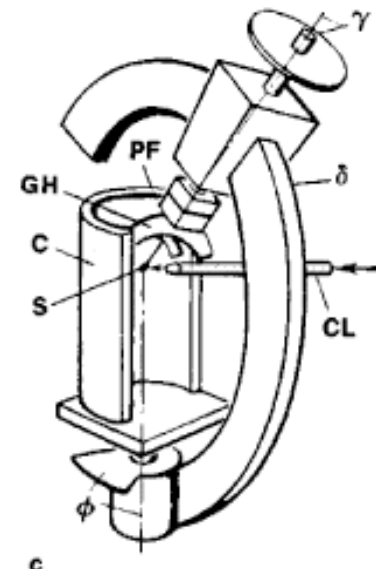
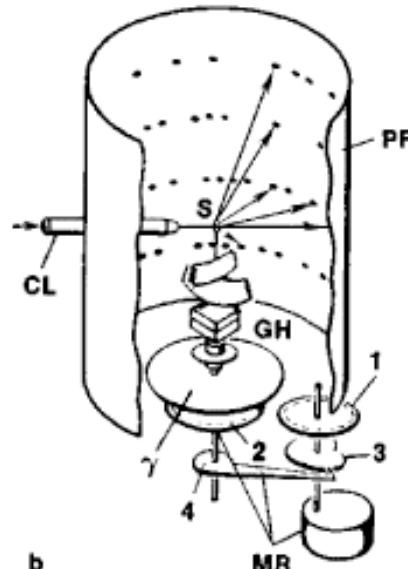
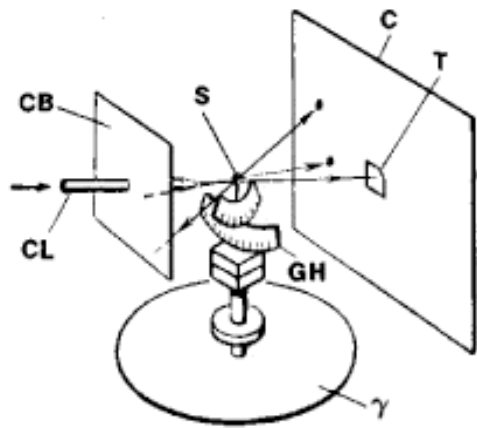
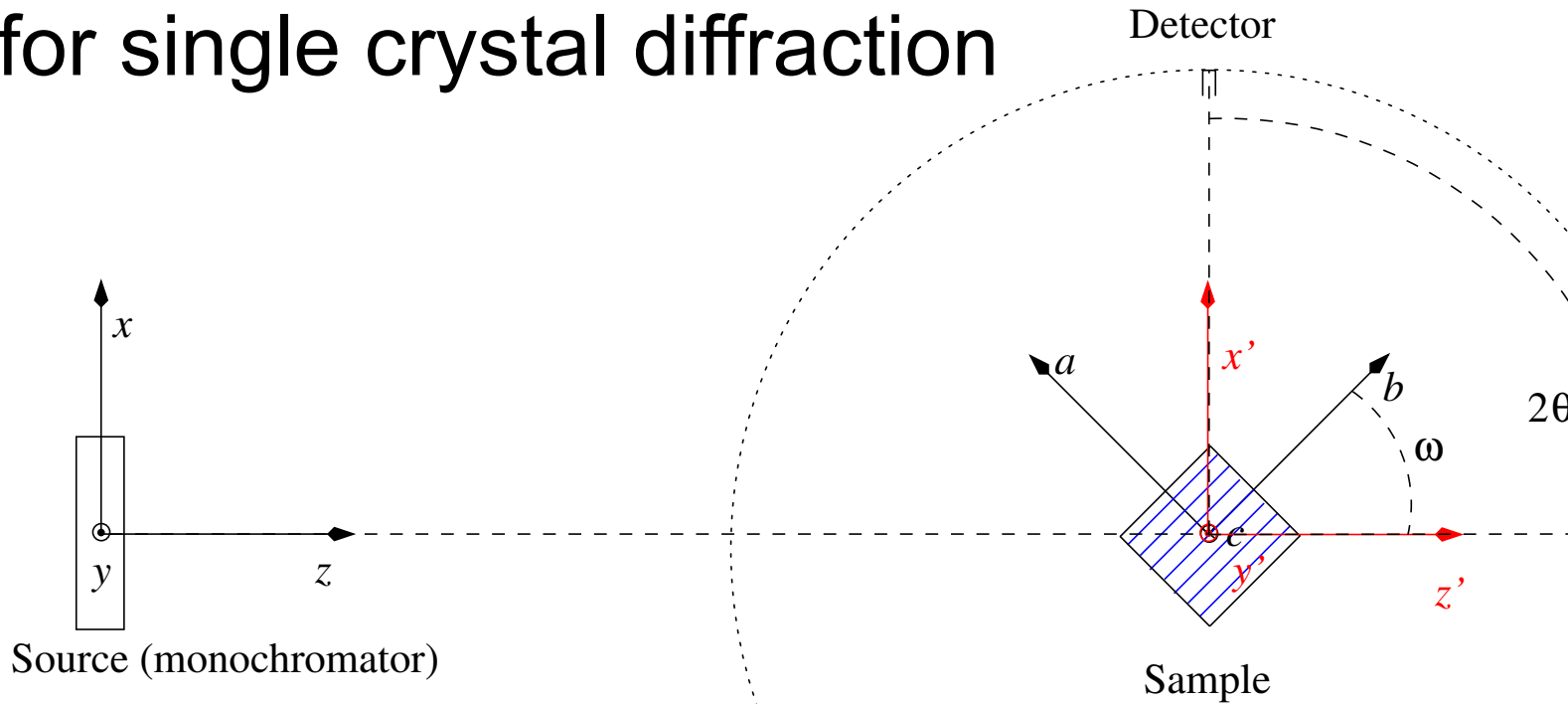

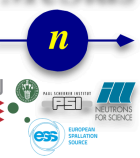

# Powder diffractometers

... for powder diffraction

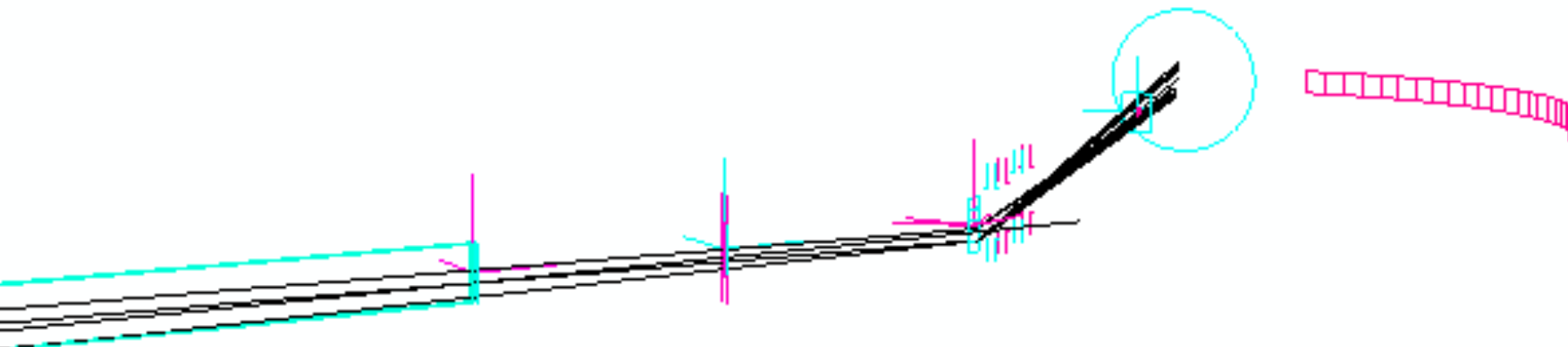
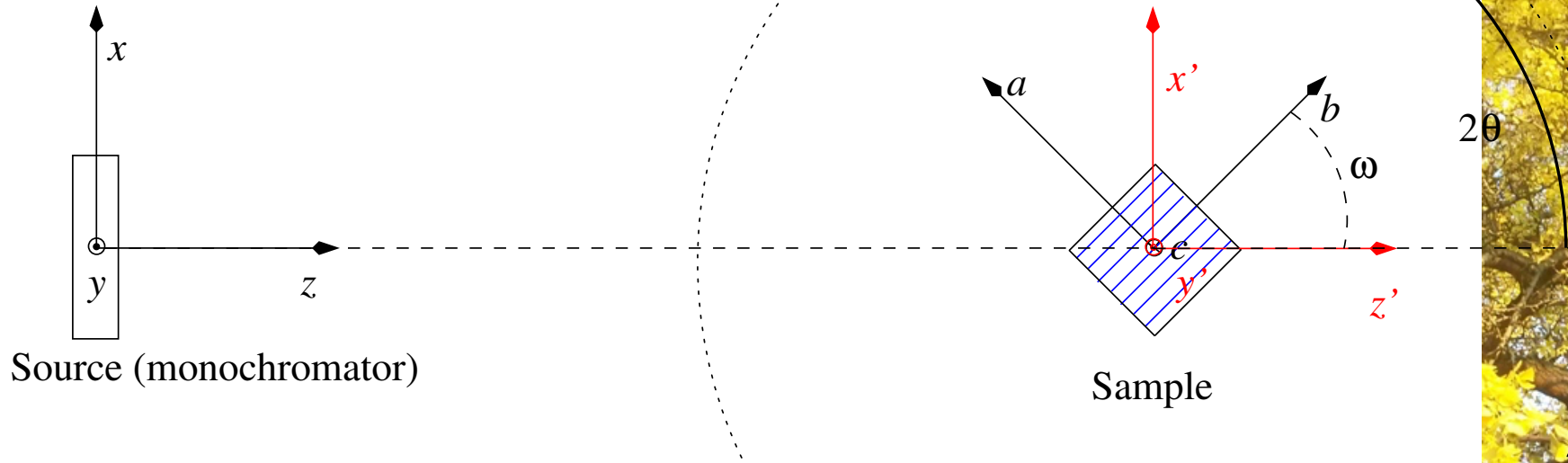

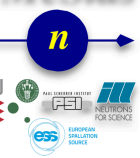

# You will now simulate both

- | Exercise 5.2 on powders
- | Exercise 5.3 on single crystals

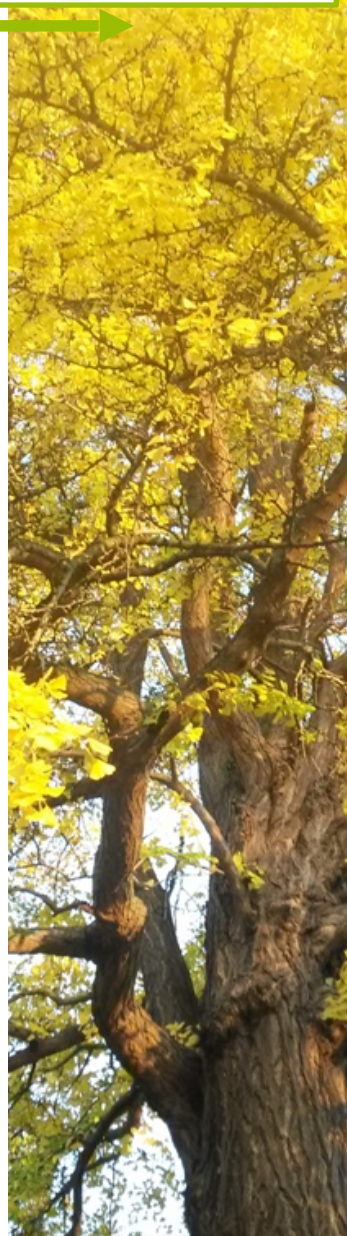



# 5.2 PowderN - intro

Among the most common materials measured with neutron scattering techniques are powders, which are composed of a large number of tiny single crystals. The scattering intensity, by means of constructive interference and averaging over all crystallites, appears as well defined rings around the out-going direct beam direction. These rings are also present in liquids, but are much smoother, as we shall see in next section.

Let us consider a material of density  $\rho$  made of  $N$  scattering units each with a unit cell volume  $V_0$  arranged with lattice spacings  $d_Q = 2\pi/Q$  associated to structure factors  $F(Q)$  with equivalent reflection multiplicities  $j_Q$ . These structure factors characterize the efficiency of the reflection with momentum exchange  $Q$ . Following Squires [14] the scattering probability for an incoming neutron with wavelength  $\lambda$  penetrating along a distance  $x$  into the material is about  $1 - \exp(-\rho\sigma_{cone} x)$  where  $\sigma_{cone}$  is the so-called coherent elastic cross-section of the ring,

$$\sigma_{cone} = \frac{N \pi \lambda^2 j_Q |F(Q)|^2}{V_0 Q} .$$

This relation is only valid under certain conditions, among which  $d_Q > \lambda/2$ , from the Bragg law. As the possible lattice spacings  $d$  in the material can not exceed a maximum value (for instance the inter-atomic distance), it appears that as the neutron wavelength increases, the number of visible rings in the diffractogram will decrease, until no more scattering is possible above the so-called *Bragg edge*, where materials become transparent to neutrons (except for absorption and incoherent scattering). This is why most of the diffractometers use thermal and hot neutrons. Cold neutrons can only scatter on large distance arrangements in materials, *e.g.* in larger molecules and proteins.



# 5.2 PowderN - construct a simple instrument file

Construct the below instrument file using mcgui....

```

/*****
* Instrument: powder_simple.instr
* %Description
* A powder scattering example.
*
* %Parameters
* lambda: [Angs] incoming neutron wavelength (monochromatic)
* material: [Angs] Powder structure file (lazy/fullprof/crystallographica)
*****/

DEFINE INSTRUMENT powder_simple (Lambda=2.36, string material="Na2Ca3Al2F14.laz")
TRACE

COMPONENT Source= Source_simple(dist=1, radius=0.01, focus_xw=0.01, focus_yh=0.01, lambda0=Lambda,
dlambda=Lambda*0.01)

AT (0,0,0) ABSOLUTE

COMPONENT powder= PowderN(reflections = material, radius = 0.005, yheight = 0.05)

AT (0,0,0.5) RELATIVE PREVIOUS

COMPONENT banana= Monitor_nD(xwidth=1, yheight=0.3, options="banana ; theta limits=[10,130] bins=240 ; y bins=50")

AT (0,0,0) RELATIVE PREVIOUS

END

```



# 5.2 - PowderN and datafiles

The equations from *Squires* relating to powders have been directly implemented in the *PowderN* component.

This handles single, coherent scattering and many *d*-spacing structure factors, with absorption correction and incoherent elastic scattering. However, no multiple or inelastic scattering is taken into account,

which the *Isotropic\_Sqw* component can cope with, in its powder mode (see exercise 9.4).

In the example at hand, we present a usage example which produces so-called Debye-Scherrer rings from a structure factor list.

The model geometry is shown in the *left* figure on next page, and the 2D ideal diffraction detector in the *right* figure on next page, for a  $\text{Na}_2\text{Ca}_3\text{Al}_2\text{F}_{14}$  reference powder. The choice of the material may be any file adapted from *Lazy/Pulverix* implemented in the

ICSD database and *Fullprof* (extension *.laz*) or *Crystallographica* (extension *.lau* also used for crystals). Currently, *McStas* includes a material data base of about 70 powder and crystal definitions commonly used in neutron scattering. These can be listed from the

*McGUI/Help/Component Library Index* menu item, and you may easily add your own materials. The material volume may be a box, a sphere and a cylinder, which all can be bulk or hollow geometries, including concentric arrangements, which we will hear about in

exercise 11.



# 5.2 Perform simulations

Please run your newly created instrument file in trace mode and simulation mode to see output like the ones below.

Investigate how the peak positions change with varied wavelength, try  $\pm 1 \text{ \AA}$  in wavelength.

Also try choosing another material from your MCSTAS/data directory.

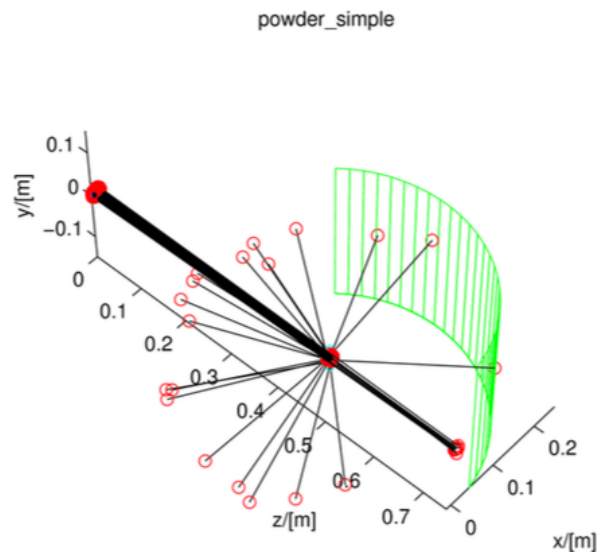

**Figure 12a.** Geometry of the *Example 8* simple powder diffraction setup, showing a few diffracted neutron trajectories. The beam is attenuated and scattered in the sample.

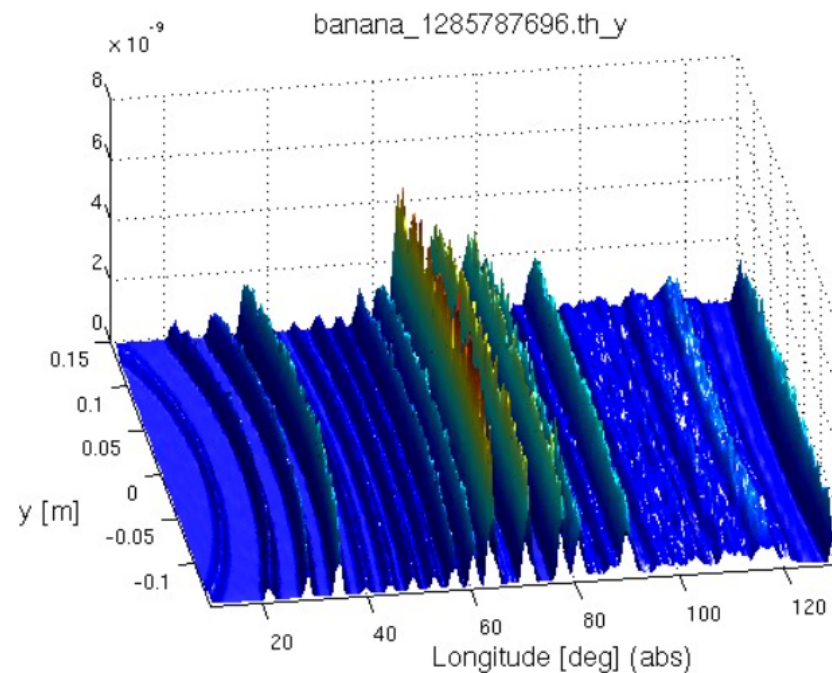

**Figure 12b.** Diffraction pattern obtained from a  $\text{Na}_2\text{Ca}_3\text{Al}_2\text{F}_{14}$  powder at  $\lambda=2.36 \text{ \AA}$ , showing intensity vs. horizontal angle vs. vertical position along the detector.

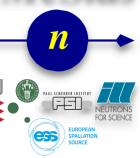

# 5.2 Optional extras

As a final optional PowderN exercise, try

- Decreasing and increasing
  - Comment on the results
- What is the effect of changing the sample size?
  - Comment on the results

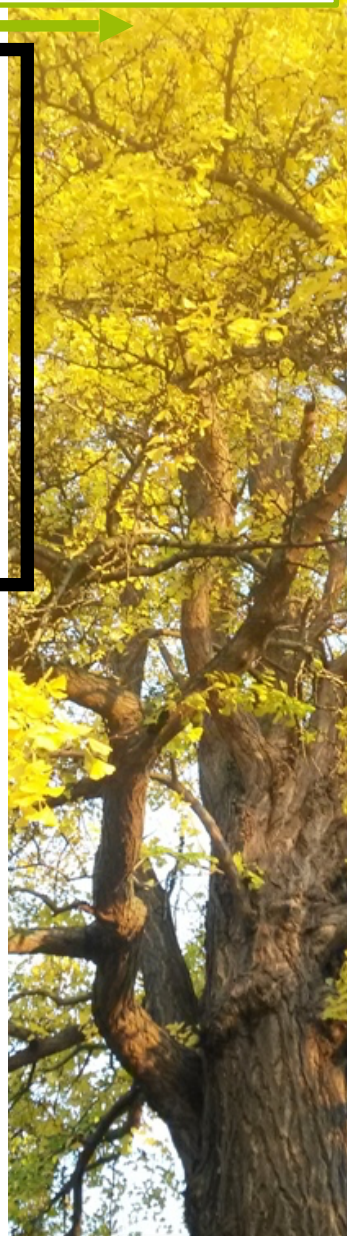

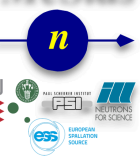

# 5.3 Single\_crystal - intro

When the sample is a single crystal, the averaging on many crystallites that is responsible for the scattering rings in a powder does not apply.

The Bragg law is still valid, but similarly as a mirror, each atomic plane selects a single reflected monochromatic ray. As there are many structural planes available, a polychromatic neutron beam will be scattered as a large number of distinct rays, forming spots on detectors.

This happens in the monochromators as discussed during the session on optics, but in this case only one reflection of interest is used, the others are scattered around, generating background.



# 5.3 Single\_crystal - construct a simple instrument file

Construct the below instrument file using mcgui....

```

/*****
* Instrument: single_crystal.instr
* %Description
* A single crystal scattering example.
*
* %Parameters
* lambda: [Angs] neutron wavelength selected by the monochromator
*****/

DEFINE INSTRUMENT single_crystal (Lambda=1, string material="C_graphite.lau")

TRACE
COMPONENT Source= Source_simple(dist=1, radius=0.01, focus_xw=0.01, focus_yh=0.01, lambda0=Lambda, dlambd=0.2*Lambda)

AT (0,0,0) ABSOLUTE

COMPONENT SX = Single_crystal(
xwidth = 0.002, yheight = 0.1, zdepth = 0.1, mosaic = 30, reflections = material, barns=0, ax=0, ay=2.14,az=1.24,
bx=0, by=0, bz= 2.47, cx=6.71,cy=0, cz= 0, sigma_abs = 0.014, sigma_inc = 0.004)

AT (0,0,0.5) RELATIVE PREVIOUS

ROTATED (0,45,0) RELATIVE PREVIOUS

COMPONENT banana= Monitor_nD(xwidth=1, yheight=1, options="banana ; theta limits=[10,130] bins=240 ; y bins=100")

AT (0,0,0.5) RELATIVE Source

END

```

This component models coherent and incoherent elastic scattering, with multiple scattering and secondary absorption.

The material volume may be a box, a sphere and a cylinder, which all can be bulk or hollow geometries, including concentric arrangements.

The instrument geometry resembles the previous one for PowderN, now with a tilted graphite plate at the sample. As expected, the scattering shows a number of spots, which each select a single wavelength. The central spot is the direct, transmitted beam.

Currently, McStas does not provide simple ways to add inelastic scattering on top of a mono-crystalline structure, even though there is a way to simulate the neutron scattering on a a simple phonon dispersion.

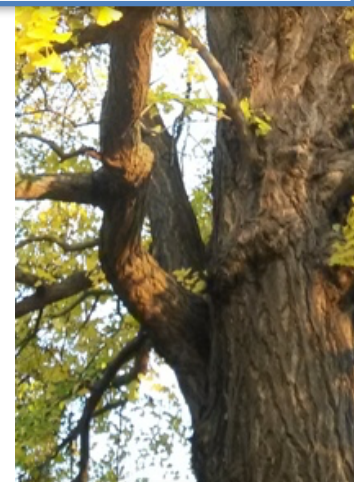



# 5.3 Perform simulations

- Now perform trace to see that all looks OK, then a simulation that should give you output like this:

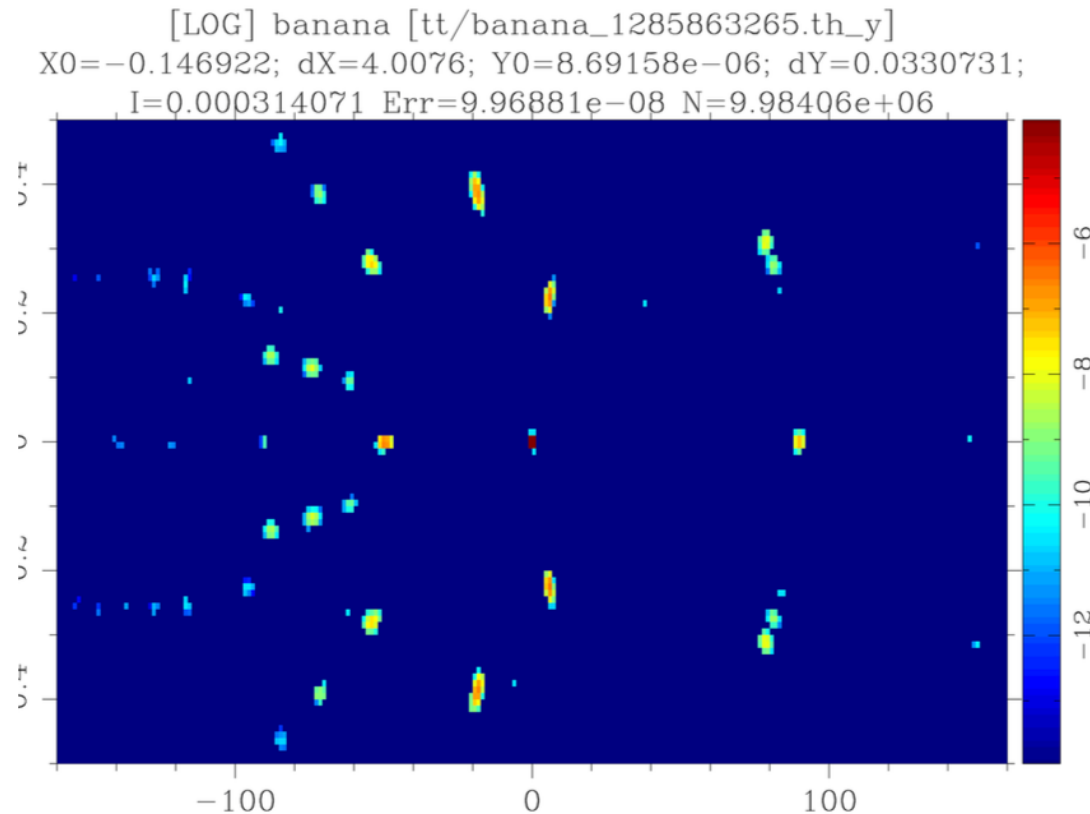

**Figure 14.** Neutron scattering from a single crystal of graphite from a neutron beam around  $\lambda=1 \text{ \AA}$ , obtained from the *Example 10*. Intensity is shown as a function of the horizontal angle and vertical coordinate, in log scale, with colors ranging from blue (low) to red (high).

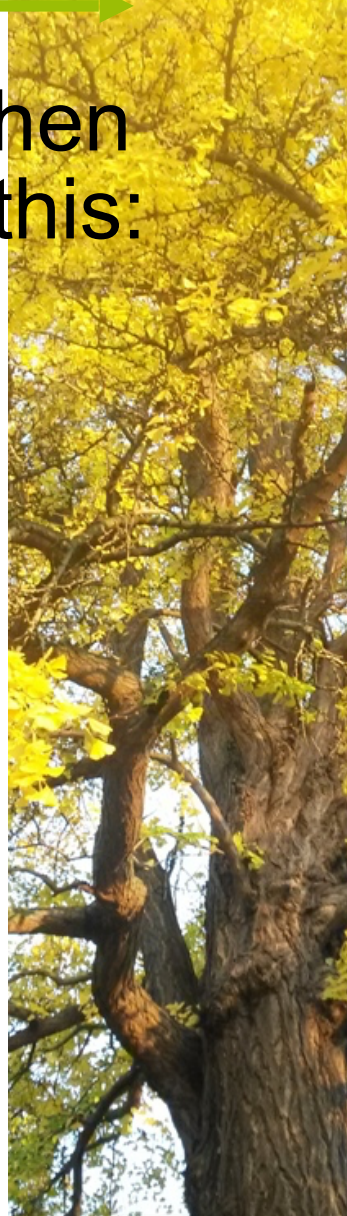

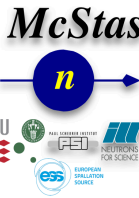

# 5.3 Optional extras

1 Create an instrument input parameter *omega* to allow rotating the sample.

1 Perform a *scan and look in the subfolders how the spots move on the detector.*

1 Also try

- Decreasing and increasing the wavelength spread
- Comment on the results

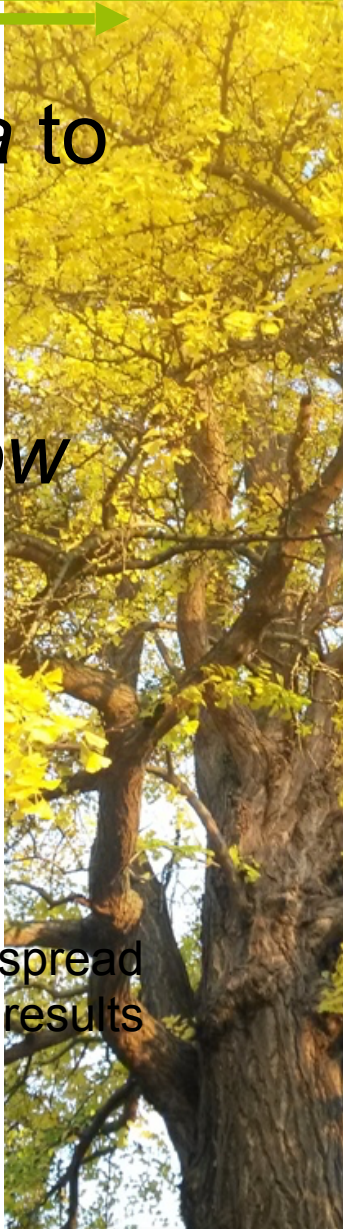

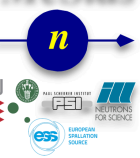

# 9.3 Optional extras

An additional complex geometry enables to use any point set to describe the material volume (*geomview* OFF file).

Try the same simulations with an OFF file from the MCSTAS/data directory

